

3000 SERIES BLANKET GAS REGULATORS

A Blanket Gas Regulator supplies an inert gas to prevent a vacuum from developing when liquid is removed from a tank, to maintain the desired blanket pressure when the temperature drops, and to prevent outside air from contaminating the tank or creating a flammable or explosive environment.

Model Numbers:



3011L // 3011H
3011HP // 3020A
3041L // 3041H
3041HP

FEATURES

- Simple operation, spring-loaded “push-push” balanced piston design
- Bubble-tight shut-off
- Variable orifice, field-adjustable flow capacity
- Single stage regulator
- Setting ranges from 0.5 InWC to 15 psig
- Set pressure is field adjustable
- Modulating opening
- Minimal lockup and droop

BENEFITS

- Low maintenance cost
- Provides optimum gas blanketing of tank and product being stored
- Prevents evaporation of product and reduces corrosion of tank by providing blanketing gas in vapor space
- Prevents a flammable or explosive environment in the tank vapor space
- Ensures pressure is maintained in the vapor space of a storage tank
- Eliminates the need for a multiple regulator system or for complicated pilot operated blanketing

MATERIALS

- Available in 316SS or other material by request



WHY GAS BLANKETING?

Blanket Gas Regulators from Groth Corporation ensure that a constant gas pressure is maintained in the vapor space of a storage tank. A blanket gas regulator supplies an inert gas to prevent a vacuum from developing when liquid is removed from a tank, to maintain the desired blanket pressure when the temperature drops, and to prevent outside air from contaminating the tank or creating a flammable or explosive environment. A blanket gas pressure as low as 0.5InWC prevents outside air and moisture from entering the storage vessel and reduces evaporation of the stored product to a negligible amount. The end result: product conservation and significant reduction in tank emissions.

The simple design of a Groth blanket gas regulator eliminates the need for a multiple regulator system or complicated pilot operated blanketing valves. Groth units have totally balanced chambers to offer high accuracy and reliability, and ensure a leak-tight design without the need for a pilot valve to operate the unit, thus reducing maintenance costs.

Groth blanket gas regulators provide a controlled gas environment in storage tanks for the following applications:

- Refineries
- Chemical & Petrochemical Plants
- Liquid Bulk Storage Terminals
- Pulp & Paper Plants
- Food & Beverage Storage

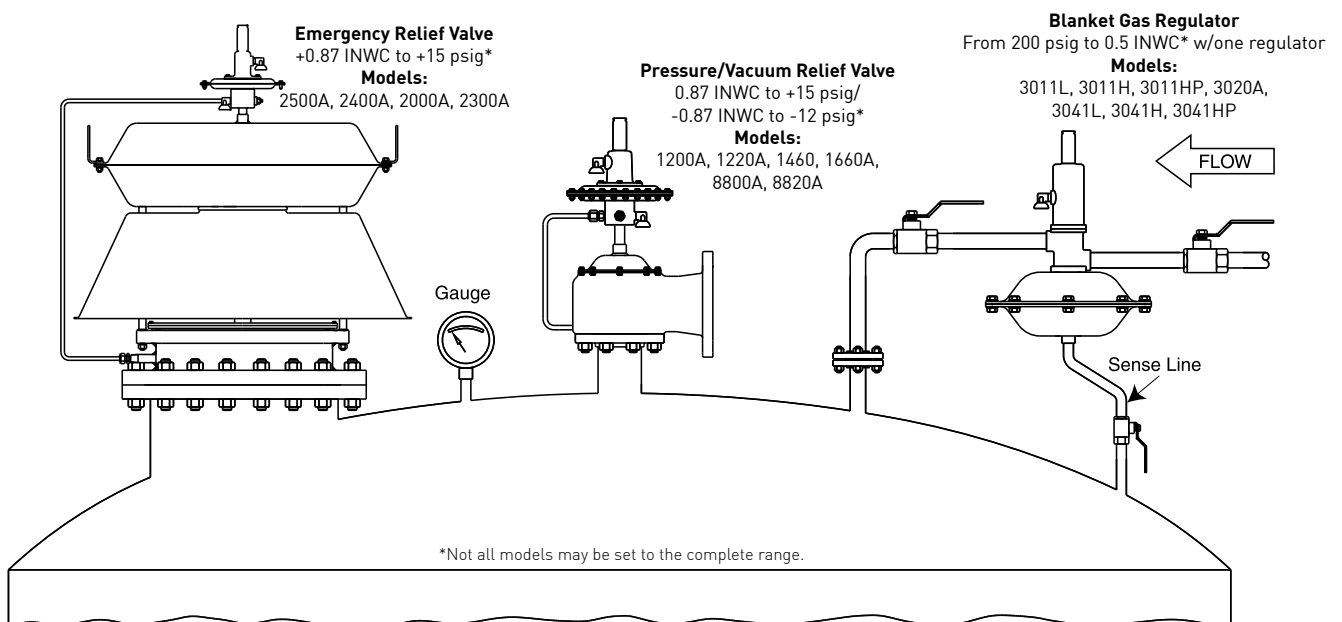

OPTIMUM PROTECTION

For optimum protection of a tank and to meet all regulatory requirements, each tank should be protected by 1) a properly-sized blanket gas regulator, to maintain the vapor pressure in the tank, 2) a properly-sized pressure/vacuum relief valve or pilot operated valve, to release the vapor during pump-in or thermal expansion, and 3) a properly-sized emergency relief valve to protect against pressure rise due to external fire. Tank protection systems can be combined across multiple tanks, but careful consideration must be given to provide adequate relief and input capacity and to prevent fouling or clogging of system piping. Consult the factory for assistance in these situations.

A Groth blanket gas regulator will prevent evaporation or contamination of product by maintaining the proper atmosphere and pressure on the product stored in a tank. A Groth pressure/vacuum relief valve or pilot operated valve with vacuum relief will prevent vapor from escaping into the atmosphere until the set pressure is exceeded, and provide vacuum protection in case of a gas supply failure. The emergency relief valve will provide vessel protection under control system failure or external fire conditions. The complete system can be provided by Groth Corporation.

Benefits of storage tank blanketing are recognized by the following government regulations and industrial standards:

- API Standard 2000
- ISO 28300
- EPA Publication AP-42
- NFPA 69 - Standard on Explosion Prevention Systems
- OSHA Part 1910.110



3011H BGR (*Cutaway Shown*)

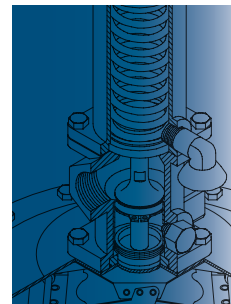

OPERATION

The Groth blanket gas regulator maintains vapor pressure in a tank by opening the supply gas valve when tank pressure (through a sense port) falls below the specified set pressure. When tank pressure is at or above the set pressure, the plate diaphragm is held up by tank pressure. Through the force-multiplying actuator arms, the piston is held up against the spring pressure, and the supply valve is closed bubble-tight. When the tank pressure falls below the set pressure, the spring force overcomes the pressure. The piston moves down, and supply gas is released into the tank.

The actuating piston has identical effective areas on the lower piston seal and the o-ring. This balances the opening and closing forces caused by supply pressure; variable gas supply pressure will not have an effect on regulator operation, which eliminates the need for an external pilot control. Pressure against the diaphragm provides direct action against the spring. This “push-push” design provides maximum force to operate the regulator and to provide a bubble-tight seal.

The flow capacity can be limited by the rotatable orifice selector sleeve. Reducing the blanket gas flow capacity may reduce the need for excessive pressure relieving capacity on smaller tanks. The sleeve is field adjustable from 100% to 5% capacity, and can be locked down to prevent tampering.

FLOW CAPACITY

Required flow capacity should be determined by using API 2000 | ISO 28300 or the relevant sizing standard. To find the rated capacity for your application, please refer to Table 1, Flow Capacity. Capacity is listed as a function of supply pressure for three typical blanket gases: CO₂, nitrogen, and natural gas. The flow capacities in the table are achieved with the 100% orifice selection. For reduced capacity, multiply the table values by the reduced percentage.

Table 1 Flow Capacity (Applies to Models 3011L, 3011H, 3011HP, 3020A, 3041L, 3041H, and 3041HP.)

Supply Pressure		Flow Capacity 1/2"						Flow Capacity 1"					
		Carbon Dioxide		Nitrogen		"Natural Gas 0.6 S.G."		Carbon Dioxide		Nitrogen		"Natural Gas 0.6 S.G."	
psig	barg	SCFH	NCMH	SCFH	NCMH	SCFH	NCMH	SCFH	NCMH	SCFH	NCMH	SCFH	NCMH
5	0.34	2160	58	2810	75	3660	98	4600	123	5800	155	7400	198
10	0.69	3250	87	4230	113	5490	147	7100	190	8800	236	11300	303
15	1.03	4370	117	5690	152	7390	198	9200	246	11500	308	14600	391
20	1.38	5130	137	6680	179	8680	233	11200	300	14000	375	17900	480
30	2.07	6630	178	8630	231	11210	300	15100	405	18900	506	24000	643
40	2.76	8140	218	10590	284	13760	369	18800	504	23600	632	30000	804
50	3.45	9650	259	12560	336	16320	437	22500	603	28200	756	35800	959
60	4.14	11160	299	14520	389	18860	505	26000	697	32600	873	41500	1110
80	5.52	14180	380	18440	494	23950	642	33000	884	41300	1110	52600	1410
100	6.89	17200	461	22370	599	29060	779	40000	1070	50100	1340	63700	1710
120	8.27	20210	541	26290	704	34150	915	47000	1260	58800	1580	74800	2000
140	9.65	23230	622	30220	810	39250	1050	53900	1440	67500	1810	85900	2300
160	11.0	26240	703	34140	915	44340	1190	60900	1630	76300	2040	97000	2600
180	12.4	29260	784	38060	1020	49440	1320	67900	1820	85000	2280	108100	2900
200	13.8	32280	865	41990	1120	54540	1460	74900	2010	93700	2510	119200	3190

Note: Unless otherwise specified, the orifice selector sleeve is factory set at 100% capacity.

NOTE: Product parameters are based on United States customary units. Metric units are provided for reference only.

MODEL SELECTION

TABLE 2 POSITIVE PRESSURE MODEL SELECTION GUIDES

1/2" BLANKET GAS REGULATOR

PRESSURE SETTING	Supply Pressure psig / barg			
	5 to 50	>50 to 100	>100 to 150	>150 to 200
	0.34 to 3.4	3.4 to 6.9	6.9 to 10.3	10.3 to 13.8
0.5 InWC to >1.0 InWC 1.2 to 2.5 mbarg				3011L
1.0 InWC to >1.5 InWC 2.5 to 3.7 mbarg	3011H			
1.5 InWC to >2.0 InWC 3.7 to 5.0 mbarg				
2.0 InWC to 6.5 InWC 5.0 to 16 mbarg				

TABLE 3 VACUUM MODEL SELECTION GUIDES

1/2" BLANKET GAS REGULATOR

VACUUM SETTING	Supply Pressure psig / barg			
	5 to 50	>50 to 100	>100 to 150	>150 to 200
	0.34 to 3.4	3.4 to 6.9	6.9 to 10.3	10.3 to 13.8
0.5 InWC to <1.0 InWC 1.2 to 2.5 mbarg				3041L
1.0 InWC to <1.5 InWC 2.5 to 3.7 mbarg	3041H			
1.5 InWC to <2.0 InWC 3.7 to 5.0 mbarg				
2.0 InWC to 6.5 InWC 5.0 to 16 mbarg				

1" BLANKET GAS REGULATOR

PRESSURE SETTING	Supply Pressure psig / barg			
	5 to 50	>50 to 100	>100 to 150	>150 to 200
	0.34 to 3.4	3.4 to 6.9	6.9 to 10.3	10.3 to 13.8
0.5 InWC to <1.0 InWC 1.2 to 2.5 mbarg				3011L
1.0 InWC to <1.5 InWC 2.5 to 3.7 mbarg				
1.5 InWC to <2.0 InWC 3.7 to 5.0 mbar	3011H			
2.0 InWC to <6.5 InWC 5.0 to 16 mbarg	3011HP			
6.5 InWC to <2.0 psig 16 to 140 mbarg				
2.0 psig to 15 psig 0.14 to 1.0 barg				

1" BLANKET GAS REGULATOR

VACUUM SETTING	Supply Pressure psig / barg			
	5 to 50	>50 to 100	>100 to 150	>150 to 200
	0.34 to 3.4	3.4 to 6.9	6.9 to 10.3	10.3 to 13.8
0.5 InWC to <1.0 InWC 1.2 to 2.5 mbarg				3041L
1.0 InWC to <1.5 InWC 2.5 to 3.7 mbarg				
1.5 InWC to <2.0 InWC 3.7 to 5.0 mbarg	3041H			
2.0 InWC to <6.5 InWC 5.0 to 16 mbarg	3041HP			
6.5 InWC to <2.0 psig 16 to 140 mbarg				

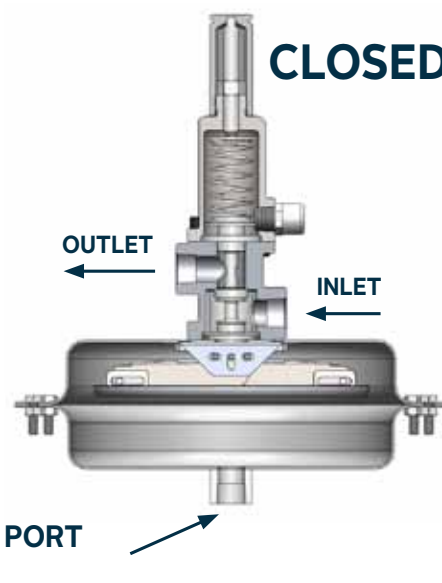
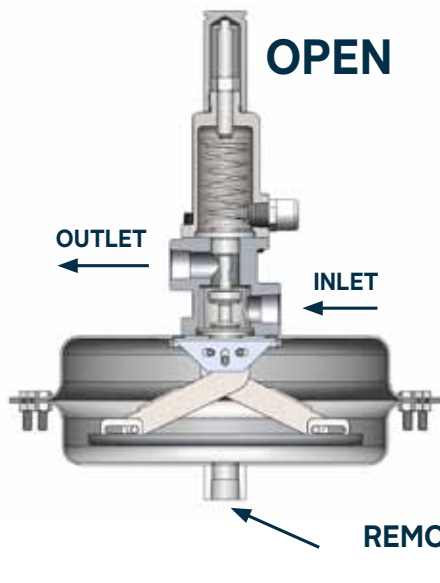

NOTE: Product parameters are based on United States customary units. Metric units are provided for reference only.

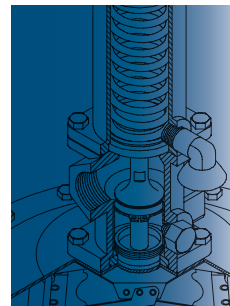

SPECIFICATIONS

TABLE 4 MIN/MAX PRESSURES
1/2" BLANKET GAS REGULATOR

Model Number	Actuator Maximum Allowable Working Pressure (MAWP)	Shipping Weight
	psig barg	lb kg
3011L	2.0 0.13	13 5.9
3041L	2.0 0.13	13 5.9
3011H	8.0 0.55	10 4.5
3041H	8.0 0.55	10 4.5

1" BLANKET GAS REGULATOR

Model Number	Actuator Maximum Allowable Working Pressure (MAWP)	Shipping Weight Lb (kg)
3011L	2 psig 0.13 barg	33 15
3011H	8 psig 0.55 barg	24 11
3011HP	25 psig 1.7 barg	24 11
3020A	75 psig 5.1 barg	15 7
3041L	2 psig 0.13 barg	33 15
3041H	8 psig 0.55 barg	29 13
3041HP	25 psig 1.7 barg	24 11



NOTE: Product parameters are based on United States customary units. Metric units are provided for reference only.

SPRING RANGES

TABLE 5 SPRING RANGES
1/2" BLANKET GAS REGULATOR

Model No.	Max Supply	Min Setting	Max Setting	Spring Range
	psig barg	InWC mbarg	InWC mbarg	
3011L/ (3041L)	200	0.5	0.8	2
	13.8	1.2	2.0	
	200	0.8	1.0	3
	13.8	2.0	2.5	
	150	0.5	0.7	1
	10.3	1.2	1.7	
	200	0.7	1.7	2
	13.8	1.7	4.2	
3011H/ (3041H)	200	1.7	3.0	3
	13.8	4.2	7.5	
	200	3.0	4.5	4
	13.8	7.5	11.2	
	200	4.5	6.5	5
	13.8	11.2	16.0	

NOTES:

- When spring ranges overlap, select the lighter spring
- Consult the factory for vacuum regulator with setting greater than 2 psig



3011L BGR

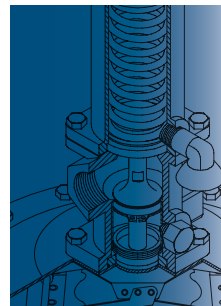

1" BLANKET GAS REGULATOR

Model Number	Max Supply	Min Setting	Max Setting	Spring Range
	psig barg	InWC mbarg	InWC mbarg	
3011L/ (3041L)	200	0.5	0.8	3
	13.8	1.2	2.0	
	200	0.8	1.0	4
	13.8	2.0	2.5	
	200	1.0	2.0	5
	13.8	2.5	5.0	
	50	0.5	1.0	1
	3.4	1.2	2.5	
	100	1.0	1.5	2
	6.9	2.5	3.7	
3011H/ (3041H)	150	1.5	2.0	3
	10.3	3.7	5.0	
	200	2.0	3.5	4
	13.8	5.0	8.7	
	200	3.5	6.5	5
	13.8	8.7	16.0	

Model Number	Max Supply	Min Setting	Max Setting	Spring Range
	psig barg	InWC mbarg	InWC mbarg	
3011HP/ (3041HP)	200	6.5	11.1	2
	13.8	16	28	
	200	11.1	18.6	3
	13.8	28	46	
	200	18.6	1.00 psig	4
	13.8	46	69	
	200	1.0 psig	1.38 psig	5
	13.8	69	95	
	200	1.38 psig	2.0 psig	6
	13.8	95	140	
3020A	200	2.0 psig	3.3 psig	4
	13.8	140	230	
	200	3.3 psig	5.1 psig	5
	13.8	230	350	
	200	5.1 psig	7.3 psig	6
	13.8	350	500	
	200	7.3 psig	15.0 psig	7
	13.8	500	1000	

NOTE: Product parameters are based on United States customary units. Metric units are provided for reference only.

HOW TO ORDER STANDARD BGRs

For easy ordering, select proper model number

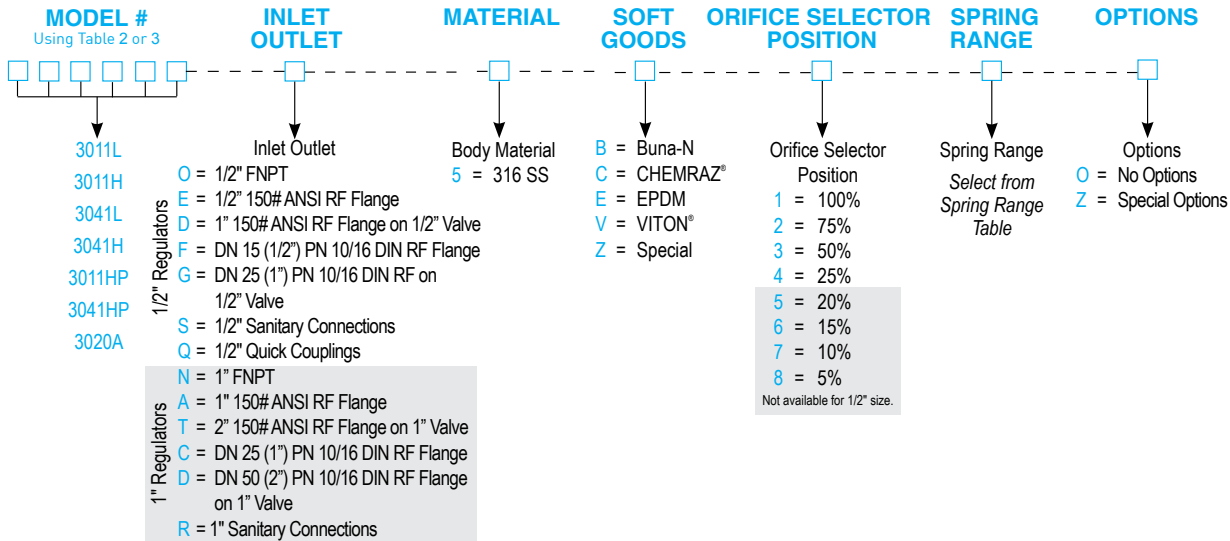

EXAMPLE

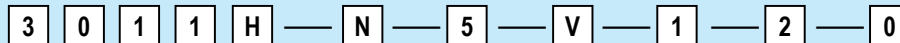

Indicates a Model 3011H Regulator with 1" FNPT body connections, 316 SS construction, VITON® elastomers, full capacity orifice, set pressure range from 1.0 InWC to 1.5 InWC and no special requirements.

ORDERING NOTES

- > Include model number when ordering
- > For special options, consult factory
- > See flow table for available sizes
- > Consult the factory for regulators with settings less than -2 psig
- > Actuator diaphragm is only available in PFA



SMART RELIEF... SAFE SOLUTIONSSM

VITON® is a registered trademark of DuPont Performance Elastomers // CHEMRAZ® is a registered trademark of Greene, Tweed & Co

 <p>GROTH CORPORATION a Continental Disc company</p>	 <p>Continental Disc Corporation</p>	<p>GROTH CORPORATION 13650 N. Promenade Blvd. Stafford, TX 77477 Ph (281) 295-6800 Fax (281) 295-6999 sales@grothcorp.com grothcorp.com</p>	<p>www.grothcorp.com</p> 
<p>THE NETHERLANDS Energieweg 20 2382 NJ Zoeterwoude-Rijndijk The Netherlands Ph +(31) 71 5412221 Fax +(31) 71 5414361 cdcnl@contdisc.com</p>	<p>CHINA Room 910, Tower B, COFCO Plaza No. 8 JianGuoMenNei Avenue Beijing (100005), P.R. China Ph +(86) 10 522 4885 Fax +(86) 10 6522 2885 cdcchina@contdisc.com</p>	<p>INDIA 423/P/1, Mahagujarat Industrial Estate, Moraiya, Sarkhej-Bavla Road, Ahmedabad (GJ) 382213 INDIA Ph +(91) 2717 619 333 Fax +(86) 10 6522 2885 gcmpl@contdisc.com</p>	